

# Keyboard

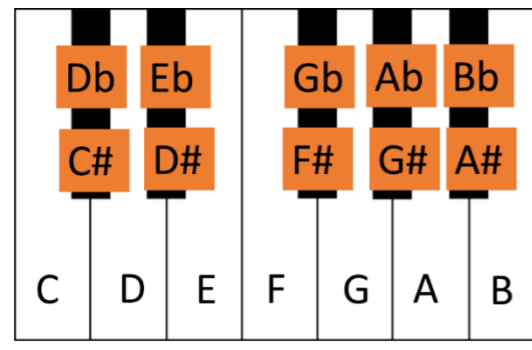

LOW

HIGH



# MUSIC

Interpretative

Timing

Projection

Musicality

Spatial Awareness

Facial Expressions

skills

# physical

- Strength** – Muscular power
- Flexibility** – Range of movements in the joints
- Alignment** – placement of body parts in relation to another – usually in a line
- Stamina** – ability to maintain physical and mental energy over a long period of time
- Posture** – the way the body is held
- Extension** – lengthening one or more muscles or limbs
- Control** – ability to start and stop movement, change direction and hold a shape
- Balance** – a steady or head position – achieved by an even distribution of weight.

## Key Words

- Tonality:** Happy/Sad
- Dynamics:** Loud/Quiet
- Loops**
- Mood / Genre**
- MAJOR / MINOR**
- Pitch:** High/Low
- Audio / Midi Recording**
- Tempo:** Fast/Slow
- Consonance / Dissonance**
- Sonority/Timbre**

**Chords:** Two or more notes played together at the same time. A chord is created by playing note numbers 1, 3, 5.

## Chords



C Major – Tonic I

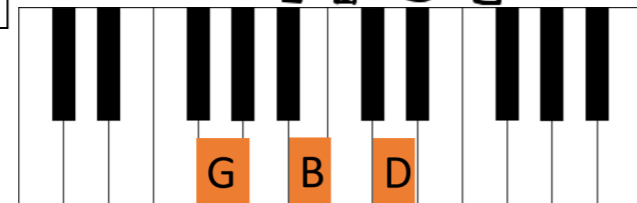

G Major – Dominant V

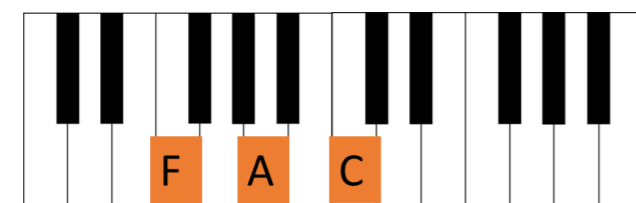

F Major – Subdominant IV

## motif

A sequence of movements.  
Often includes: relationships, actions, dynamics and space (RADS)

## Professional Works

- Swansong**
- Choreographer:** Christopher Bruce
- Theme:** Human Rights
- Characters:** 1 prisoner and 2 Guards

# DANCE

# DRAMA

## Dramatic Techniques

- Still Image
- Improvisation
- Soundscape
- Movement

stage directions

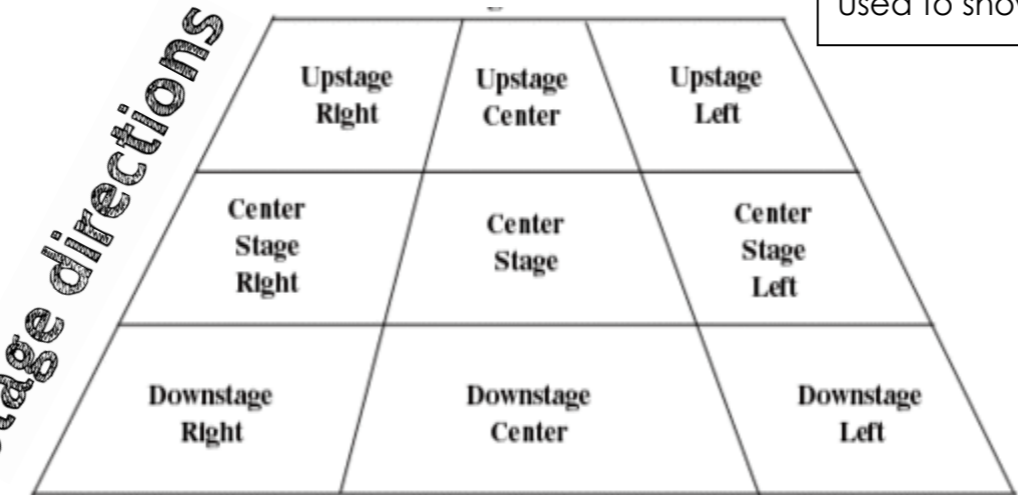

Use of height by a character. Can be used to show status.

Proxemics: The space between characters to show a relationship

physical skills	vocal skills
Levels	Clarity
Facial Expressions	Accent
Body Language	Volume
Space	Pitch
Posture	Pace
Gesture	Tone